



Known For Reliability For Over 87 Years

The BIRO B350M is designed to provide trouble free service in a WET MEAT ROOM ENVIRONMENT with features such as Waterproof Motor, Electrical Components and Connections plus Non-Corrosive Metals, all of which add to the water resistant benefits of this slicer.

- Blade - 13-3/4" (350mm) Hollow Ground Alloy Steel will allow a slicing capacity to nearly 10" on round products at a thickness from 0 to 1" (25mm) slice. Index knob has indicator positions showing rotation of one millimeter increments for consistency within multiple slicing stations.

- Design - Low profile of 23" in height and minimum of removable parts allow for easy clean-up while the ergonomic easy glide carriage reduces fatigue and simplifies effort for the operator.

- Built In Safety Features - Blade protective ring guard prevents exposed blade edge when the blade cover is removed for cleaning. Product table lockout prevents thickness gauge from being opened during cleaning. Emergency shut-off and thermal overload/no volt release prevents accidental turn on after power outages. Remote sharpener mounts easily when needed but is stored away from the slicer when not in use providing added hygiene security to the slicing operation.

- BIRO - This trusted name has over 85 years experience in bringing quality products with value to your meat room operation.



B350M



*Stands alone for quality
and value since 1921*

SPECIFICATIONS

| | |
|----------------------------|--|
| MODEL | B350M GRAVITY FEED MANUAL SLICER. |
| CONSTRUCTION | BODY - ANODIZED POLISHED ALUMINUM CAST WITH NON-CORROSIVE METAL FRAME. |
| MOTORS | IP 65 - 1/2 HP (.35 KW) 115V 60 HZ 1 PH INTERNALLY COOLED. (STANDARD U.S VOLTAGE) IP 65 - 1/2 HP (.35 KW) 220V 60 HZ 1 PH INTERNALLY COOLED. IP 65 - 1/2 HP (.35 KW) 220V 50 HZ 1 PH INTERNALLY COOLED. |
| STANDARD FEATURES | BLADE - 13-3/4" (350 MM) HOLLOW GROUND ALLOY STEEL - 200 RPM. OVERSIZED PRODUCT TABLE. MAXIMUM PRODUCT CUT - ROUND 9.84" (250 MM). MAXIMUM PRODUCT CUT - RECTANGULAR 12-1/2" (318 MM) X 9" (230 MM). AUTOMATIC SPRING LOADED BELT TENSIONING. BLADE PROTECTIVE RING GUARD PREVENTS EXPOSED BLADE EDGE DURING CLEANING. TILT-AWAY PRODUCT TABLE LOCKOUT PREVENTS THICKNESS GAUGE FROM BEING OPENED DURING CLEANING. THERMAL OVERLOAD/NO VOLT RELEASE PREVENTS ACCIDENTAL TURN ON AFTER POWER OUTAGES. GREEN PUSHBUTTON ON/OFF CONTROL AND RED E-STOP BUTTON. MOTOR - IP 65-1/2 HP 115V 60 HZ 1 PH INTERNALLY COOLED POLYGROOVE BELT DRIVE PROVIDING OPTIMUM PERFORMANCE WATER RESISTANT IP 65 MOTOR, WIRING HARNESS, ELECTRONIC CONTROLS, CONNECTORS. DETACHED SHARPENER ASSEMBLY - HELPS PROVIDE HYGIENIC SLICING AREA. PRODUCT FENCE - FOR USE ON NARROW PRODUCTS. |
| CERTIFICATION | NSF, ETL, ETL, ETL-SANITATION, CE. |
| WEIGHT | UNCRATED - 77 LBS. (35 KG). CRATED - 114 LBS. (52 KG). |
| DIMENSIONS UNCRATED | LENGTH (DEPTH) - 22" (560 MM) FOOT TO FOOT, SPACE 32" (813 MM) OVERALL. WIDTH - 17" (432 MM) FOOT TO FOOT, SPACE 28" (711 MM) OVERALL. HEIGHT - 23" (584 MM). |
| DIMENSIONS CRATED | L = 33" (838 MM) X W = 28" (711 MM) X H = 28" (711 MM). |

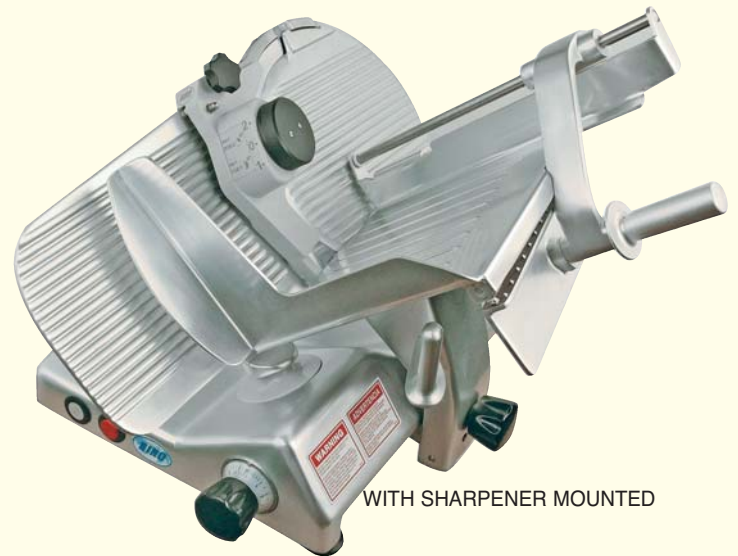

WITH SHARPENER MOUNTED

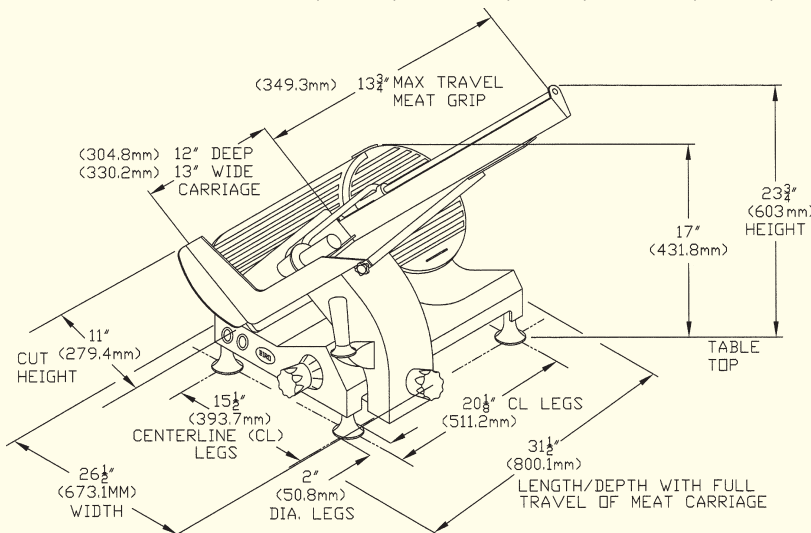

ALL SPECIFICATIONS CONTAINED HEREIN ARE SUBJECT TO CHANGE WITHOUT NOTIFICATION.

THE BIRO MANUFACTURING COMPANY
1114 WEST MAIN STREET
MARBLEHEAD, OH 43440-2099 U.S.A.
Phone: (419) 798-4451
Fax: (419) 798-9106
<http://www.birosaw.com>
sales@birosaw.com

ITEM NO.: LIT-B350M-335

FORM NO.: Md B350M-335-01-09-2

Service is available from over 245 locations worldwide